



Advantages

Watertight Design - The hinged, locking, watertight cover and solid body design prevents rainwater from getting into the spill container.

Cover Options - Includes FRC raintight in API colors, FRC black snap-on, raintight aluminum, watertight locking aluminum and cast iron.

API Cover Identification Plates - All FRC colored covers have a recessed area on the top for a product identification plate. The identification plate clearly identifies the product contained in the storage tank. Identification plates are available for all standard API symbols.

Highway 20 Rated (D.O.T. H20) - All EBW spill containers and manways exceed the D.O.T. H20 requirements.

Auto-Drain - Conforming to certain state and local regulations, the auto-drain is a ball float drain valve that automatically allows product to drain when the product is present.

Optional Cover Actuated Push Drains (C.A.P.D.) - As the spill container cover is closed and locked in place, the drain is automatically activated, allowing any spilled product to drain into the tank.

Centering-Ring - A styrofoam centering-ring is used during installation to easily align the grade level manway with the below grade spill container.

- CARB: EVR Certification VR-103 (7XX-49Y-0Z models).

Materials

- Base: cast iron or composite.
- Bucket: polyethylene
- Manway cover: fiber reinforced composite steel.
- Cover: cast iron.

702, 705 and 715 Below Grade Level Spill Containers

EBW below grade spill containers are equipped with a hinged, locking, watertight cover, eliminating water and debris infiltration. A grade level manway with FRC cover is installed above the spill container to allow surface water to drain into the soil and away from the spill container. Models are available with cast iron or composite threaded base, slip-on (retrofit) base, standard pull drain valve, and black composite or API color covers. Steel covers are available in lieu of standard black FRC covers at no additional charge.

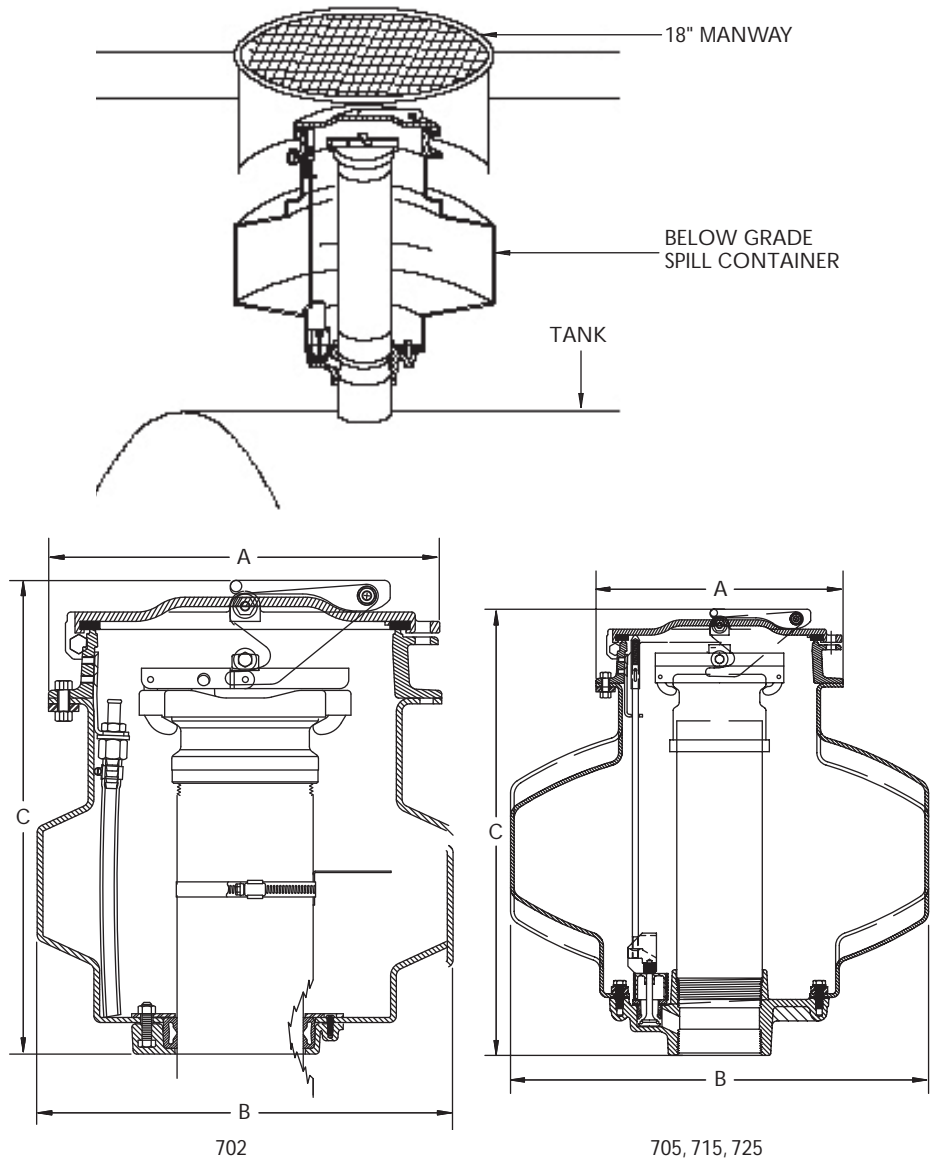

Model	A		B		C	
	In.	cm	In.	cm	In.	cm
702	13.00	33.02	13.75	34.90	15.88	40.30
705	13.00	33.02	13.75	34.92	17.69	44.93
715	13.00	33.02	22.00	55.88	23.44	59.54

Composite Base Spill Containers

Model, with drain	Capacity		Cover	Weight	
	Gallon	Liter		Lbs.	Kg
705-475-01-BLK*	5	19	Black, FRC, 18"	86.00	39.00

Cast Iron Base Spill Containers

Model, with drain	Capacity		Cover	Weight	
	Gallon	Liter		Lbs.	Kg
705-445-01-BLK	5	19	Black, FRC, 18"	68.00	31.20
705-474-01-BLK*	5	19	Black, FRC, 18"	94.00	43.00
705-474-65-BLK*	5	19	Black, FRC, 18", RCA	131.00	60.20
705-492-01-BLK**	5	19	Black, FRC, 18"	94.00	43.00
715-474-01-BLK*	15	57	Black, FRC, 18"	96.00	43.50
715-474-65-BLK*	15	57	Black, FRC, 18", RCA	100.00	45.40
715-492-01-BLK**	15	57	Black, FRC, 18"	100.00	45.40

Model, without drain	Capacity		Cover	Weight	
	Gallon	Liter		Lbs.	Kg
705-477-ND-BLK*	5	19	Black, FRC, 18", RCA	130.00	59.00
705-492-02-BLK**	5	19	Black, FRC, 18"	94.00	43.00
715-492-02-BLK**	15	57	Black, FRC, 18"	100.00	45.40

*ULC approved, MH21091

**CARB Phase 1 approved, VR-103



702, 705



715

18" Manway Cover Options

Suffix	Description
BLK	Black, raintight, FRC
WHT	White, raintight, FRC
RED	Red, raintight, FRC
YEL	Yellow, raintight, FRC
ORG	Orange, raintight, FRC
STL	Steel
NC	No cover, FRC



CENTERING-RING

Replacement 18" Manway Covers

Suffix	Description
781-304-01	FRC black, raintight
781-304-02	FRC white, raintight
781-304-03	FRC red, raintight
781-304-05	FRC yellow, raintight
781-304-07	FRC orange, raintight
781-306-01	Steel



COVER OPTIONS

Retrofit Spill Containers

Model, with pump	Capacity		Cover	Weight	
	Gallon	Liter		Lbs.	Kg
702-450-01-BLK*	5	19	Black, FRC, 18"	39.00	17.70
702-450-65*	5	19	No cover, with skirt	39.00	17.70