

IMPORTANT: OPW products should be used in compliance with applicable federal, state, provincial, and local laws and regulations. Product selection should be based on physical specifications and limitations and compatibility with the environment and materials to be handled. OPW MAKES NO WARRANTY OF FITNESS FOR A PARTICULAR USE. All illustrations and specifications in this literature are based on the latest product information available at the time of publication. OPW reserves the right to make changes at any time in prices, materials, specifications and models and to discontinue models without notice or obligation.



**OPW 104 Series Cast Iron Manholes (104A-0800 104A-1200 104A-1219 104FG-1200 104FG-1219 104A-1800 104A-1819)**



### **OPW 104A Cast Iron Manhole**

A sturdy steel skirt on the standard 104A extends nearly a foot below grade to ensure trouble-free installation in deep concrete, and optional skirts that extend a full 19 1/4" below grade are available in 12" and 18" diameters for sandy soil locations.

### **OPW 104FG Cast Iron Manhole**

The 104FG provides a convenient finger grip feature on the cover to facilitate cover removal.

**Table of Contents:**

1. Features
2. Dimensions
3. Ordering Specifications
4. Replacement Parts
5. Additional Resources

## Features

---

- **Full-size internal diameters for maximum access and working area**
- **Highway 20 Rated (H20)** - All OPW spill containers and manholes exceed the requirements of the Highway 20 rating.
- **Rugged cast iron covers and body rings**
- **Cast-in non-skid finish on covers**
- **Sturdy, extra long steel skirts**
- **Individually boxed for ease of handling**

## Materials

Body ring: cast iron

Cover: cast iron

Skirt: galvanized steel

OPW 104A/FG

---

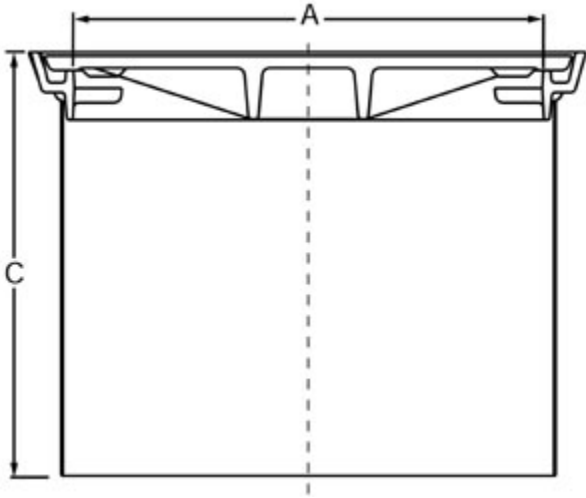

OPW 104A/FG Cast Iron Cover Manhole

OPW 104A

---

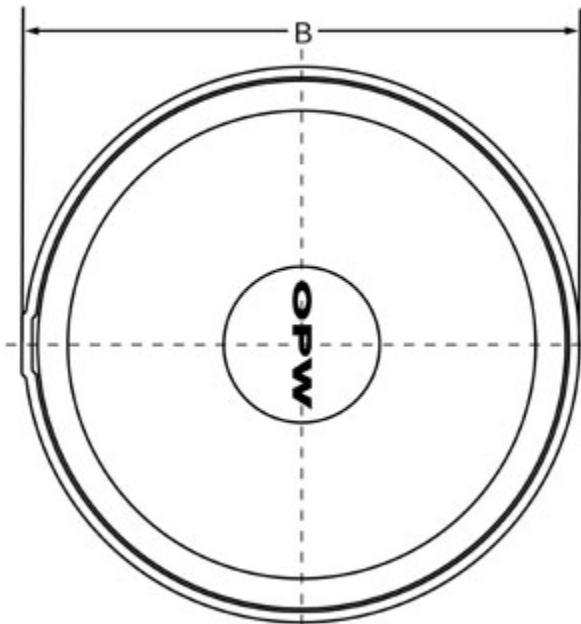

## OPW 104A Cover

### Dimensions

---

Product No.	A		B		C	
	in	cm	in	cm	in	cm
104A-0800	8"	20.3	10 1/8"	25.7	11 1/4"	28.6
104A/FG-1200	12"	30.5	14 1/4"	36.2	11 1/4"	28.6
104A/FG-1219	12"	30.5	14 1/4"	36.2	19 1/4"	48.9
104A-1800	18"	45.7	20 1/8"	51.1	11 1/4"	28.6
104A-1819	18"	45.7	20 1/8"	51.1	19 1/4"	48.9

## Ordering Specifications

---

Product No.	ID (in.)	ID (mm.)	lbs.	kg.
104A-0800	8"	203	15	6.8
104A-1200	12"	305	28	12.7
104A-1219	12"	305	33	15.0
104FG-1200*	12"	305	28	12.7
104FG-1219*	12"	305	33	15.0
104A-1800	18"	457	50	22.7
104A-1819	18"	457	57	25.9

\*Finger Grip Cover Manhole

## Replacement Parts

---

Part No.	Description
E00508M	Cover for 8" 104A-0800
E00510M	Cover for 12" 104A-1200
E00584M	Cover for 12" 104FG-1200
E00512M	Cover for 18" 104A-1800
D01747M	Cover for 20" 104C-2000

## Obsolete Parts

---

Obsolete Bucket	Replacement Lid	Cover O.D.
104A-1022	C00115M	8.44"
104A-1066	D00173M	13.125"
104AC-1586	D00173I	13.125"
104AOW-1212	E00299M	13.125"

## Installation Procedure

---

[104A Clearance.PDF](#)



